

Tandy 1000 SX

Disk Drive Kit

Owner's Manual

TERMS AND CONDITIONS OF SALE AND LICENSE OF TANDY COMPUTER EQUIPMENT AND SOFTWARE PURCHASED FROM RADIO SHACK COMPANY-OWNED COMPUTER CENTERS, RETAIL STORES AND RADIO SHACK FRANCHISEES OR DEALERS AT THEIR AUTHORIZED LOCATIONS

LIMITED WARRANTY

I. CUSTOMER OBLIGATIONS

- A. CUSTOMER assumes full responsibility that this computer hardware purchased (the "Equipment"), and any copies of software included with the Equipment or licensed separately (the "Software") meets the specifications, capacity, capabilities, versatility, and other requirements of CUSTOMER.
- B. CUSTOMER assumes full responsibility for the condition and effectiveness of the operating environment in which the Equipment and Software are to function, and for its installation.

II. LIMITED WARRANTIES AND CONDITIONS OF SALE

- A. For a period of ninety (90) calendar days from the date of the Radio Shack sales document received upon purchase of the Equipment, RADIO SHACK warrants to the original CUSTOMER that the Equipment and the medium upon which the Software is stored is free from manufacturing defects. **This warranty is only applicable to purchases of Tandy Equipment by the original customer from Radio Shack company-owned computer centers, retail stores, and Radio Shack franchisees and dealers at their authorized locations.** The warranty is void if the Equipment or Software has been subjected to improper or abnormal use. If a manufacturing defect is discovered during the stated warranty period, the defective Equipment must be returned to a Radio Shack Computer Center, a Radio Shack retail store, a participating Radio Shack franchisee or a participating Radio Shack dealer for repair, along with a copy of the sales document or lease agreement. The original CUSTOMER'S sole and exclusive remedy in the event of a defect is limited to the correction of the defect by repair, replacement, or refund of the purchase price, at RADIO SHACK'S election and sole expense. RADIO SHACK has no obligation to replace or repair expendable items.
- B. RADIO SHACK makes no warranty as to the design, capability, capacity, or suitability for use of the Software, except as provided in this paragraph. Software is licensed on an "AS IS" basis, without warranty. The original CUSTOMER'S exclusive remedy, in the event of a Software manufacturing defect, is its repair or replacement within thirty (30) calendar days of the date of the Radio Shack sales document received upon license of the Software. The defective Software shall be returned to a Radio Shack Computer Center, a Radio Shack retail store, a participating Radio Shack franchisee or Radio Shack dealer along with the sales document.
- C. Except as provided herein no employee, agent, franchisee, dealer or other person is authorized to give any warranties of any nature on behalf of RADIO SHACK.
- D. **EXCEPT AS PROVIDED HEREIN, RADIO SHACK MAKES NO EXPRESS WARRANTIES, AND ANY IMPLIED WARRANTY OF MERCHANTABILITY OR FITNESS FOR A PARTICULAR PURPOSE IS LIMITED IN ITS DURATION TO THE DURATION OF THE WRITTEN LIMITED WARRANTIES SET FORTH HEREIN.**
- E. Some states do not allow limitations on how long an implied warranty lasts, so the above limitation(s) may not apply to CUSTOMER.

III. LIMITATION OF LIABILITY

- A. **EXCEPT AS PROVIDED HEREIN, RADIO SHACK SHALL HAVE NO LIABILITY OR RESPONSIBILITY TO CUSTOMER OR ANY OTHER PERSON OR ENTITY WITH RESPECT TO ANY LIABILITY, LOSS OR DAMAGE CAUSED OR ALLEGED TO BE CAUSED DIRECTLY OR INDIRECTLY BY "EQUIPMENT" OR "SOFTWARE" SOLD, LEASED, LICENSED OR FURNISHED BY RADIO SHACK, INCLUDING, BUT NOT LIMITED TO, ANY INTERRUPTION OF SERVICE, LOSS OF BUSINESS OR ANTICIPATORY PROFITS OR CONSEQUENTIAL DAMAGES RESULTING FROM THE USE OR OPERATION OF THE "EQUIPMENT" OR "SOFTWARE." IN NO EVENT SHALL RADIO SHACK BE LIABLE FOR LOSS OF PROFITS, OR ANY INDIRECT, SPECIAL, OR CONSEQUENTIAL DAMAGES ARISING OUT OF ANY BREACH OF THIS WARRANTY OR IN ANY MANNER ARISING OUT OF OR CONNECTED WITH THE SALE, LEASE, LICENSE, USE OR ANTICIPATED USE OF THE "EQUIPMENT" OR "SOFTWARE." NOTWITHSTANDING THE ABOVE LIMITATIONS AND WARRANTIES, RADIO SHACK'S LIABILITY HEREUNDER FOR DAMAGES INCURRED BY CUSTOMER OR OTHERS SHALL NOT EXCEED THE AMOUNT PAID BY CUSTOMER FOR THE PARTICULAR "EQUIPMENT" OR "SOFTWARE" INVOLVED.**
- B. RADIO SHACK shall not be liable for any damages caused by delay in delivering or furnishing Equipment and/or Software.
- C. No action arising out of any claimed breach of this Warranty or transactions under this Warranty may be brought more than two (2) years after the cause of action has accrued or more than four (4) years after the date of the Radio Shack sales document for the Equipment or Software, whichever first occurs.
- D. Some states do not allow the limitation or exclusion of incidental or consequential damages, so the above limitation(s) or exclusion(s) may not apply to CUSTOMER.

IV. SOFTWARE LICENSE

RADIO SHACK grants to CUSTOMER a non-exclusive, paid-up license to use the TANDY Software on **one** computer, subject to the following provisions:

- A. Except as otherwise provided in this Software License, applicable copyright laws shall apply to the Software.
- B. Title to the medium on which the Software is recorded (cassette and/or diskette) or stored (ROM) is transferred to CUSTOMER, but not title to the Software.
- C. CUSTOMER may use Software on a multiuser or network system only if either, the Software is expressly labeled to be for use on a multiuser or network system, or one copy of this software is purchased for each node or terminal on which Software is to be used simultaneously.
- D. CUSTOMER shall not use, make, manufacture, or reproduce copies of Software except for use on **one** computer and as is specifically provided in this Software License. Customer is expressly prohibited from disassembling the Software.
- E. CUSTOMER is permitted to make additional copies of the Software **only** for backup or archival purposes or if additional copies are required in the operation of **one** computer with the Software, but only to the extent the Software allows a backup copy to be made. However, for TRSDOS Software, CUSTOMER is permitted to make a limited number of additional copies for CUSTOMER'S own use.
- F. CUSTOMER may resell or distribute unmodified copies of the Software provided CUSTOMER has purchased one copy of the Software for each one sold or distributed. The provisions of this Software License shall also be applicable to third parties receiving copies of the Software from CUSTOMER.
- G. All copyright notices shall be retained on all copies of the Software.

V. APPLICABILITY OF WARRANTY

- A. The terms and conditions of this Warranty are applicable as between RADIO SHACK and CUSTOMER to either a sale of the Equipment and/or Software License to CUSTOMER or to a transaction whereby Radio Shack sells or conveys such Equipment to a third party for lease to CUSTOMER.
- B. The limitations of liability and Warranty provisions herein shall inure to the benefit of RADIO SHACK, the author, owner and/or licensor of the Software and any manufacturer of the Equipment sold by Radio Shack.

VI. STATE LAW RIGHTS

The warranties granted herein give the **original** CUSTOMER specific legal rights, and the **original** CUSTOMER may have other rights which vary from state to state.

6.86

Introduction

Congratulations on your purchase. Adding a second floppy disk drive to your Tandy 1000 SX significantly increases the amount of disk storage on your computer.

Installation

We recommend that you have the secondary disk drive installed by the service technicians at your Radio Shack Service Center. Doing so not only ensures expert installation, but also enables the technicians to quickly check to be sure all the equipment is functioning properly.

If, however, you do decide to install the kit yourself, follow these steps exactly:

Warning: Turn off all equipment. Disconnect the power cord from the back of the computer. If the computer is on, you could damage the central processing unit, as well as your secondary disk drive.

1. To avoid possible static charge buildup, touch a metal object to ground yourself before you begin.
2. The Tandy 1000 SX Disk Drive Kit consists of the following parts:
 - the disk drive
 - three small screws

Be sure the disk drive in this kit matches the disk drive in your computer. Pay special attention to the drive light and door latch. They should be positioned the same as those in the drive in your computer. If they do not match, see your Radio Shack dealer.

3. Remove the two screws on the front of the main unit. Remove the cover by sliding it away from the rear of the unit, parallel to the computer.

Figure 1

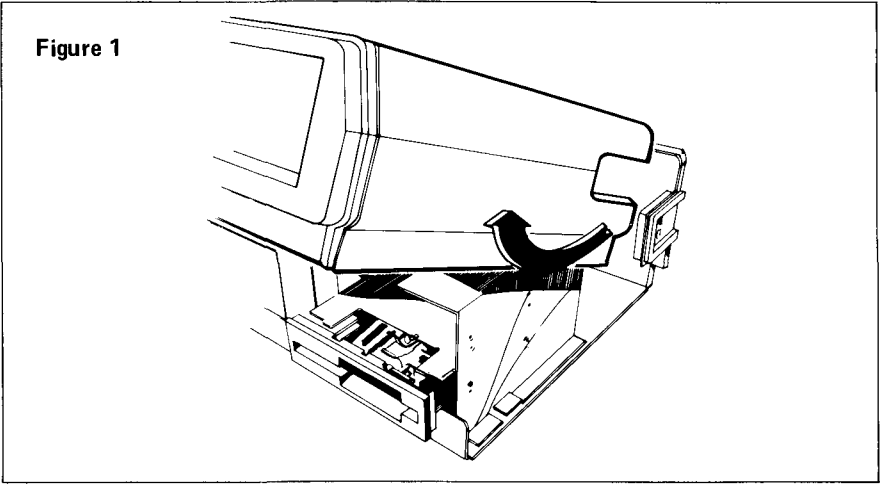

4. Facing the front of the main unit, locate the screws on the right side that hold the primary drive (lower drive) in place. It might be helpful to loosen these screws (without removing them) so that you can use the main unit as a reference for securing the new disk drive.

Note: Right and left mean you right or your left as you face the computer.

5. Slide the disk drive into the drive mount directly above the first drive. Be sure that the drive light and door latch are on the same side as they are on the primary drive. See Figure 2.

Figure 2

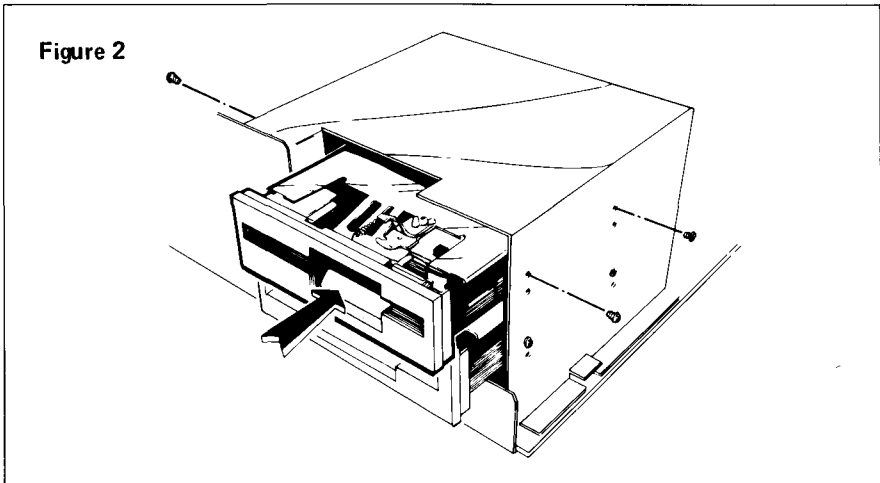

6. Insert the two small screws (included) into the mounting holes on the right side of the drive mount bracket. Notice that the drive mount bracket has an upper and lower set of holes for each drive. When mounting the secondary drive, place the screws in the set of holes that corresponds to the set used for the first drive. See Figure 2.

For example, if the first drive's screws are in the lower set of holes, use the lower set of holes for the second drive, and vice versa.

Do not tighten the screws yet.

Hint: You may have to lift the drive slightly to align the holes.

7. Insert the remaining screw into the left side of the drive. Only one hole will line up with a corresponding hole in the drive mount bracket.
8. Tighten all screws of both drives.
9. Look at the backs of the drives, and locate the 34-pin ribbon cable that is attached to the first drive. Connect the other end of the cable to the card edge on the right side of the second drive. Do not twist the cable. Refer to Figure 3.

10. Next, connect the four-pin power connector to the connector next to the card edge. You can connect this connector in only one way. Do not force it.

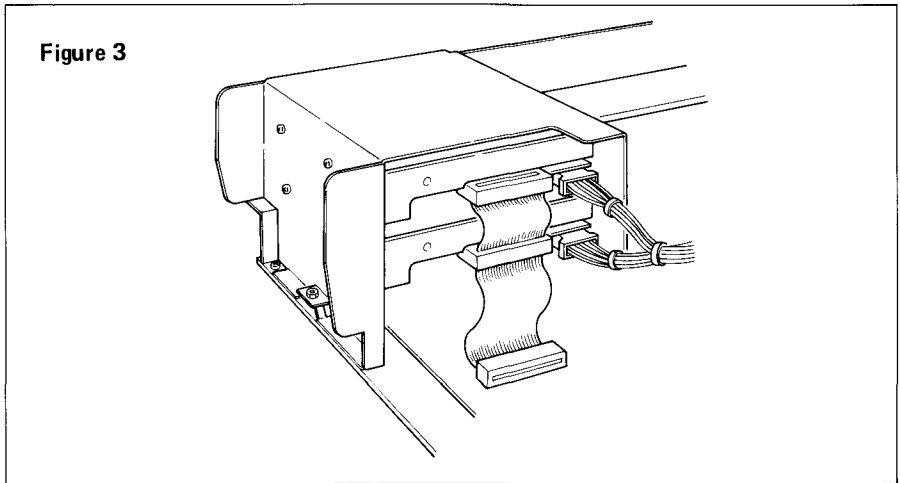

11. Remove the plastic panel that covers the drive opening in the case by placing both thumbs on the outside of the cover and pushing in evenly. The panel should pop out.
12. Before replacing the main unit's cover, check all connections, and be sure all screws are tightened.
13. Replace the main unit's cover and screws.
14. Carefully remove the shipping card from the drive slot.

You can now use your new disk drive on your Tandy 1000 SX. See your introduction manual or your applications manual for instructions on using data diskettes.

Note: The small screws that came in this kit may have metric threads. If you lose one, your Radio Shack dealer can order a replacement.

SERVICE POLICY

Radio Shack's nationwide network of service facilities provides quick, convenient, and reliable repair services for all of its computer products, in most instances. Warranty service will be performed in accordance with Radio Shack's Limited Warranty. Non-warranty service will be provided at reasonable parts and labor costs.

RADIO SHACK
A Division of Tandy Corporation
Fort Worth, Texas 76102